

CHANGE

NO. 1

**HEADQUARTERS
DEPARTMENT OF THE ARMY
Washington, D.C., 1 DECEMBER 2001**

MODIFICATION WORK ORDER

VEHICLE	MODEL	NSN
Truck, Utility, 1-1/4 Ton, 4x4:		
Cargo/Troop Carrier	M998	2320-01-107-7155
Cargo/Troop Carrier	M998A1	2320-01-371-9577
Cargo/Troop Carrier, W/W	M1038	2320-01-107-7156
Cargo/Troop Carrier, W/W	M1038A1	2320-01-371-9578
Tow Carrier, Armored	M966	2320-01-107-7153
Tow Carrier, Armored	M966A1	2320-01-372-3292
Armament Carrier, Armored	M1025	2320-01-128-9551
Armament Carrier, Armored	M1025A1	2320-01-371-9584
Armament Carrier, Armored, W/W	M1026	2320-01-128-9552
Armament Carrier, Armored, W/W	M1026A1	2320-01-371-9579

MWO 9-2320-280-20-7, 1 January 2001, is changed as follows:

1. Remove old pages and insert new pages as indicated below.
2. New or changed material is indicated by a vertical bar in the margin of the page.

Remove pages

1 and 2
5 and 6
Figures 5 and 6

Insert pages

1 and 2
5 and 6
Figures 5 and 6

3. File this change sheet in front of the publication for reference purposes.

Approved for Public Release; Distribution is Unlimited.

MWO 9-2320-280-20-7

By Order of the Secretary of the Army:

ERIC K. SHINSEKI
General, United States Army
Chief of Staff

Official:

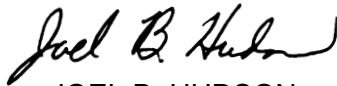

JOEL B. HUDSON
Administrative Assistant to the
Secretary of the Army
0127410

Distribution:

To be distributed in accordance with the initial distribution number (IDN) 381105, requirements for MWO 9-2320-280-20-7.

ROUTINE

MWO effective date is 1 January 2001 and completion date is 31 December 2004.

MWO 9-2320-280-20-7

MODIFICATION WORK ORDER

MODIFICATION OF 1-1/4 TON VEHICLES

VEHICLE	MODEL	NSN
Truck, Utility, 1-1/4 Ton, 4x4:		
Cargo/Troop Carrier	M998	2320-01-107-7155
Cargo/Troop Carrier	M998A1	2320-01-371-9577
Cargo/Troop Carrier, W/W	M1038	2320-01-107-7156
Cargo/Troop Carrier, W/W	M1038A1	2320-01-371-9578
Tow Carrier, Armored	M966	2320-01-107-7153
Tow Carrier, Armored	M966A1	2320-01-372-3292
Armament Carrier, Armored	M1025	2320-01-128-9551
Armament Carrier, Armored	M1025A1	2320-01-371-9584
Armament Carrier, Armored, W/W	M1026	2320-01-128-9552
Armament Carrier, Armored, W/W	M1026A1	2320-01-371-9579

CROSSMEMBER REINFORCEMENT

Headquarters, Department of the Army, Washington, D.C.

1 January 2001

REPORTING ERRORS AND RECOMMENDING IMPROVEMENTS

You can help improve this publication. If you find any mistakes or if you know of a way to improve the procedures, please let us know. Submit your DA Form 2028 (Recommended Changes to Equipment Technical Publications), through the Internet, on the Army Electronic Product Support (AEPS) website. The Internet address is <http://aeprs.ria.army.mil>. If you need a password, scroll down and click on "ACCESS REQUEST FORM." The DA Form 2028 is located in the ONLINE FORMS PROCESSING section of the AEPS. Fill out the form and click on SUBMIT. Using this form on the AEPS will enable us to respond quicker to your comments and better manage the DA Form 2028 program. You may also mail, fax or email your letter or DA Form 2028 direct to: AMSTA-LC-CI Tech Pubs, TACOM-RI, 1 Rock Island Arsenal, Rock Island, IL 61299-7630. The email address is TACOM-TECH-PUBS@ria.army.mil. The fax number is DSN 793-0726 or Commercial (309) 782-0726.

APPROVED FOR PUBLIC RELEASE; DISTRIBUTION IS UNLIMITED.

1. PURPOSE.

This modification provides a strengthened frame to increase towing capacity. After the vehicle is modified it will be "AUTHORIZED TO TOW TRAILERS WITH MAX GROSS WEIGHT OF 3,400 LB (1,544 KG)".

2. PRIORITY.

This modification is classified as ROUTINE.

3. END ITEM TO BE MODIFIED.

NOTE

Application will be controlled/determined by PM, LTV based on approved DCSOPS distribution plans/funding streams for HMT.

a. Selected vehicles as identified by models below and serial numbers selected by the user.

NOMENCLATURE	NSN	PART NO.	CAGEC	MODEL NO.
Truck, Utility, 1-1/4 Ton, 4x4:				
*Cargo/Troop Carrier	2320-01-107-7155	8750057	19207	M998
*Cargo/Troop Carrier	2320-01-371-9577	8750297	19207	M998A1
*Cargo/Troop Carrier, W/W	2320-01-107-7156	8750058	19207	M1038
*Cargo/Troop Carrier, W/W	2320-01-371-9578	8750326	19207	M1038A1
*Tow Carrier, Armored	2320-01-107-7153	8750055	19207	M966
*Tow Carrier, Armored	2320-01-372-3932	8750325	19207	M966A1
*Armament Carrier, Armored	2320-01-128-9551	8750082	19207	M1025
*Armament Carrier, Armored	2320-01-371-9584	8750298	19207	M1025A1
*Armament Carrier, Armored, W/W	2320-01-128-9552	8750083	19207	M1026
*Armament Carrier, Armored, W/W	2320-01-371-9579	8750299	19207	M1026A1

*Not applicable to vehicles equipped with Pintle Extension Kit, or not applicable to vehicles with shelters extending past the rear bumper.

b. Vehicle National Stock Number (NSN) will not change as a result of this MWO.

4. MODULE(S) TO BE MODIFIED.

Not applicable.

5. PART(S) TO BE MODIFIED.

Not applicable.

6. APPLICATION.

a. Time Compliance Schedule: The effective date of this MWO is 1 January 2001 and its completion date is 31 December 2004.

b. The lowest level of maintenance authorized to apply the MWO is Organizational maintenance.

c. Work force and man-hour requirements for application of the MWO to a single unit, end item, or system:

REQUIREMENTS	
WORK FORCE/SKILLS	MAN-HOURS
One Wheeled Vehicle Mechanic (MOS 63B) or equivalent	2.0
Total man-hours required for a single application of this MWO	2.0

7. TECHNICAL PUBLICATIONS AFFECTED/CHANGED AS A RESULT OF THIS MWO.

<u>Technical Publication</u>	<u>Date</u>
TM 9-2320-280-10	31 Jan 96
TM 9-2320-280-20	31 Jan 96
TM 9-2320-280-24P	31 Jan 96

8. MWO KITS, PARTS, AND THEIR DISPOSITION.

a. The following kit is required to accomplish this modification. The security classification of this kit is unclassified. Shipping data is: weight 51 lbs; the kit measures 30.5 x 9.3 x 6.5 in.; its volume is 1.067 cu ft.

<u>NSN</u>	<u>NOMENCLATURE</u>	<u>CAGEC</u>	<u>PART NO.</u>
2540-01-477-6589	Crossmember Reinforcement	19207	57K3561

b. Crossmember Reinforcement Modification Kit component parts are listed below. The listing is used to inventory the kit for completeness.

<u>NSN</u>	<u>NOMENCLATURE</u>	<u>CAGEC</u>	<u>PART NO.</u>	<u>QTY.</u>
5310-00-735-5396	Washer	19207	7355396	1
9905-00-858-5682	Plate, Instruction, MWO	19207	10930014	1
	Bracket	19207	12340275-3	1
	Bracket	19207	12340275-4	1
2590-01-188-3237	Bracket, Pioneer Tool	19207	12340286-3	1
	Tray Mounting			
	Channel	19207	12469094	1
	Bracket, Channel	19207	12469095	1
	Bracket, Channel	19207	12469096	1
	Brace	19207	12469097	2
	Decal	19207	12469442	1
5350-00-253-5614	Screw, Drive	96906	MS21318-20	1
5315-00-846-0126	Pin, Cotter	96906	MS24665-628	1
5310-00-045-3296	Lockwasher	96906	MS35338-43	8
5305-01-287-6608	Screw, Self-tapping	96906	MS51851-75	4
	Nut	81349	M45913/4-5CG8Z	2
	Nut	81349	M45913/4-8CG8Z	14
5310-01-152-0598	Nut	24617	271172	4
5306-01-360-1128	Bolt	24617	455006	2
5310-01-119-1024	Washer	24617	2436162	2
5310-01-121-1703	Washer	24617	2436165	28
5310-01-147-4052	Washer	24617	2436168	8
5306-01-186-5369	Bolt	24617	9415560	8
	Nut	24617	9419507	4
5306-00-226-4827	Screw	80204	B1821BH031C100N	2
5305-00-071-2079	Screw	80204	B1821BH050C400N	4
5305-00-947-4358	Screw	80204	B1821BH075C400N	4

c. Bulk and Expendable Material. Not applicable.

d. Parts Disposition. All parts not reused during installation will be returned to stock for disposition in accordance with AR 725-50.

9. SPECIAL TOOLS; TOOL KITS; JIGS; TEST, MEASUREMENT, AND DIAGNOSTIC EQUIPMENT (TMDE); AND FIXTURES REQUIRED.

a. Hand tools necessary to apply MWO are contained in following tool kit:

NOMENCLATURE	NSN	CAGEC	SUPPLY CATALOG
Tool Kit, General Mechanic's	5180-00-177-7033	50980	SC 5180-95-N26

b. Tools necessary to apply MWO are contained in following shop set:

NOMENCLATURE	NSN	CAGEC	SUPPLY CATALOG
Shop Equipment, Automotive Maintenance and Repair: Organizational Maintenance, Common No. 1	4910-00-754-0654	19204	SC 4910-95-A74

10. MODIFICATION PROCEDURE.

a. Vehicle Preparation.

- (1) Park vehicle and apply parking brake lever. (Refer to TM 9-2320-280-10.)
- (2) Remove pioneer tool stowage tray mounting bracket. (Refer to TM 9-2320-280-20.)
- (3) Remove tools from pioneer tool stowage tray. (Refer to TM 9-2320-280-10.)
- (4) Remove cotter pin, slotted nut, washer, and towing pintle from rear frame channel as shown in figure 1. Discard cotter pin.
- (5) Remove four locknuts, screws, cover, and receptacle from receptacle mounting bracket as shown in figure 2. Discard locknuts.

NOTE

- If receptacle mounting bracket is held on D-beam with rivets, perform step 6. If not, perform step 7.
- Sealing compound may have been used to adhere receptacle mounting to D-beam and may require some prying to remove from D-beam after hardware is removed.

- (6) Remove two rivets and receptacle mounting bracket from D-beam as shown in figure 2.
- (7) Remove two locknuts, screws, washers, and receptacle mounting bracket from D-beam as shown in figure 2. Discard locknuts.

NOTE

If receptacle mounting bracket was riveted to D-beam, enlarge both holes in receptacle mounting bracket and existing hole in D-beam on left side to 0.344-inch diameter.

- (8) Align right side hole in existing receptacle mounting bracket with left side hole on D-beam and using receptacle mounting bracket as a template, locate, mark, and drill 0.344-inch diameter hole in receptacle mounting bracket and D-beam as shown in figure 3. Remove receptacle mounting bracket.
- (9) Remove eight nuts, sixteen washers, and eight screws from two rear frame channel mounting brackets and left and right frame rails as shown in figure 4.

WARNING

Rear frame channel must be supported before removing inner brace support brackets. Failure to support rear frame channel may result in injury to personnel.

NOTE

It may be necessary to loosen mounting hardware on two rear frame channel mounting brackets in order to remove rear frame channel.

- (10) Remove two nuts, four washers, two screws, inner brace support brackets, and rear frame channel from left and right frame rails as shown in figure 4.
- (11) Remove four nuts, lockwashers, screws, and two tool tray latch strikers from rear frame channel as shown in figure 4. Discard lockwashers.
- (12) Remove four nuts, lockwashers, screws, and two latches from pioneer tool stowage tray as shown in figure 5. Discard lockwashers.

NOTE

Remove all burrs and sharp edges.

- (13) Locate, mark, and remove two metal brackets flush with frame as shown in figure 5. Prime and paint exposed surfaces. (Refer to TM 43-0139.)
- b. Crossmember Reinforcement Installation.
- (1) In the event tool latch striker holes have not been added to channel 12469094, locate, mark, and drill four 0.1495-inch (#25 drill bit) holes in channel as shown in figure 6. Tap holes to .190-24UNC-2B.
 - (2) Install 12469094 channel on 12469096 and 12469095 channel brackets with four B1821BH075C400N screws, eight 2436168 washers, and four 9419507 nuts as shown in figure 6. Do not tighten nuts.
 - (3) Install two existing tool tray latch strikers on channel with four MS51851-75 self-tapping screws and MS35338-43 lockwashers as shown in figure 6.

NOTE

It may be necessary to lift body from frame channel to align holes and start bolts.

- (4) Install channel brackets 12469096 and 12469095 on left and right frame rails with eight 9415560 bolts, sixteen 2436165 washers, and eight M45913/4-8CG8Z nuts as shown in figure 7.
- (5) Install two 12469097 braces on left and right frame rails with two 455006 bolts, four 2436165 washers, and two M45913/4-8CG8Z nuts as shown in figure 7. Do not tighten nuts.
- (6) Remove four nuts, eight washers, four screws, two support plates, backing plate, safety chain plate, and two inner brace support brackets from rear frame channel as shown in figure 8. Discard nuts, washers, screws, one support plate, locking plate, and two inner brace brackets.
- (7) Install existing safety chain plate and support plate on channel with two braces 12469097, four B1821BH050C400N screws, eight 2436165 washers, and four M45913/4-8CG8Z nuts as shown in figure 9. Do not tighten nuts.
- (8) Install towing pintle on channel with 7355396 washer and existing slotted nut and ensure washer is positioned center on bumper and tighten slotted nut as shown in figure 9. Loosen slotted nut slightly if towing pintle will not rotate easily.
- (9) Align hole in towing pintle and slotted nut and install MS24665-628 cotter pin through slotted nut and towing pintle as shown in figure 9.
- (10) Tighten nuts installed in step 1 as shown in figure 6.
- (11) Ensure both braces are on frame rails and channel and tighten nuts installed in steps 4 and 6 as shown in figures 7 and 9.

c. Pioneer Tool Stowage Tray Installation.

NOTE

Ensure mounting bracket is mounted all the way to the rear of crossmember.

- (1) Install 12340286-3 pioneer tool tray mounting bracket on rear crossmember with two existing screws and washers as shown in figure 10.
- (2) Install 12340275-3 and 12340275-4 brackets on pioneer tool stowage tray with two existing latches, four screws, MS35338-43 lockwashers, and nuts as shown in figure 10. Tighten nuts to 16-30 lb-in. (2-3 N·m).
- (3) Install tools on pioneer tool stowage tray. (Refer to TM 9-2320-280-10.)
- (4) Install pioneer tool stowage tray. (Refer to TM 9-2320-280-10.)

d. Final Vehicle Preparation.

- (1) Install receptacle mounting bracket on D-beam with two B1821BH031C100N screws, 2436162 washers, and M45913/4-5CG8Z nuts as shown in figure 11.
- (2) Install existing receptacle and existing cover on receptacle mounting bracket with four existing screws and 271172 nuts as shown in figure 11.
- (3) Install 12469442 decal on D-beam centered above tow pintle as shown in figure 12.

11. CALIBRATION REQUIREMENTS.

Not applicable to this MWO.

12. WEIGHT AND BALANCE DATA.

Weight and balance are not significantly affected by this MWO.

13. QUALITY ASSURANCE REQUIREMENTS.

a. General. The following information is furnished to ensure the proper application of this MWO and provide clarification in regard to the adequacy of installer's inspection methods and procedures applicable to Quality Assurance (QA). Inspection shall be IAW TM 750-245-4, TM 9-2320-280-10, TM 9-2320-280-20, and MWO 9-2320-280-20-7.

b. Installer Responsibilities. The installer is responsible for following instructions in MWO 9-2320-280-20-7, TM 9-2320-280-10, TM 9-2320-280-20. The installer will report Crossmember Reinforcement Modification Kits received that are damaged or missing component parts so the kit supplier can be properly notified. Any discrepancies noted will be corrected before the vehicle leaves the installer's work area. Requirements contained in this MWO shall be included in the installer's inspection plan or quality assurance program. These requirements shall not be construed as eliminating the installer's responsibility from complete compliance with provisions of the contract and submitting to the Government products that meet all requirements of the contract.

c. Government Verification. All QA operations and installation changes and inspections performed by the installer are subject to Government verification at unannounced and varying intervals. Verification will consist of observations and inspections to confirm that practices, methods, and procedures of the installer's written inspection plan are being properly applied; and that Government product inspection to confirm the quality of product offered for Government acceptance does not deviate from prescribed acceptance standards specified in TM 9-2320-280-10, TM 9-2320-280-20, and TM 750-245-4. Deviations will be brought to the attention of the installer for correction.

d. In-process Inspection. During normal assembly operations, paragraph 10, Modification Procedure, will be used to check the installer's work. After installation is complete, the vehicle will be checked IAW the PMCS checklist for correct installation and to ensure there are no defects. Any defects noted will be corrected by the installer before the vehicle is placed in service. All vehicles modified during a production shift will be checked to ensure product quality.

14. RECORDING AND REPORTING OF THE MODIFICATION.

- a. Records and Reports. The organization responsible for MWO application will report application information as follows:
- (1) Reporting will be accomplished by electronic means. MWO application information can be input directly into the Modification Management Information System (MMIS) over the internet. If internet is not available, recording will be on a 3.5-inch disk, which will be mailed to the MMIS administrator. Entry into the MMIS system is password protected. New users can register on-line at <http://208.242.67.250/mwo>. Passwords are normally approved and issued within 48 hours.
 - (2) Submission will be comprised of the nine (9) data elements listed in the table below. Elements 1,2,4,6,7,8, and 9 are given for this MWO (as shown). The person reporting the MWO data, will acquire the remaining elements (3 and 5), and input all nine into MMIS.

DATA Elements

Input Data

1. Material Change Number (MCN)
2. MWO Number
3. Unit Identification Code (UIC) @ Battalion Level
4. NSN of End Item
5. Serial Number
6. USA Registration Number
7. Date of Application
8. Hours required for Application.
9. Software Version

- (3) For off-line reporting, the 3.5-inch disk shall be mailed to the following address:
Commander
TACOM-Warren
ATTN: AMSTA-LC-CIPWM
Warren, MI 48397-5000

b. Marking Equipment.

- (1) After Crossmember Reinforcement Modification Kit is installed, mark MWO under "9-2320-280-20-7" in the MWO Applied block and date applied in Date block on 10930014 MWO instruction plate.

NOTE

Do not remove any existing MWO instruction plates affixed to the reinforcement panel.

- (2) Install MWO instruction plate 10930014 by drilling a 0.104-inch diameter hole (#37 drill bit) within designated area on left side body reinforcement panel and secure with MS21318-20 drive screw as shown in figure 13.
- (3) After drive screw is installed, flatten or remove protruding excess drive screw material from inside of side body reinforcement panel.

15. MATERIAL CHANGE (MC) NUMBER.

This MWO is authorized by (MC) number 1-00-06-0008.

16. MODIFICATION IDENTIFICATION.

- a. When installed correctly, the Crossmember Reinforcement Modification Kit will appear as shown in figure 14.
- b. After the Crossmember Reinforcement Modification Kit is installed, the tow pintle support should be inspected for secure mounting. Any faults detected, or discrepancies noted, will be corrected before the vehicle is returned to normal service
- c. After the vehicle is modified it will be "AUTHORIZED TO TOW TRAILERS WITH MAX GROSS WEIGHT OF 3,400 LB (1,544 KG)".

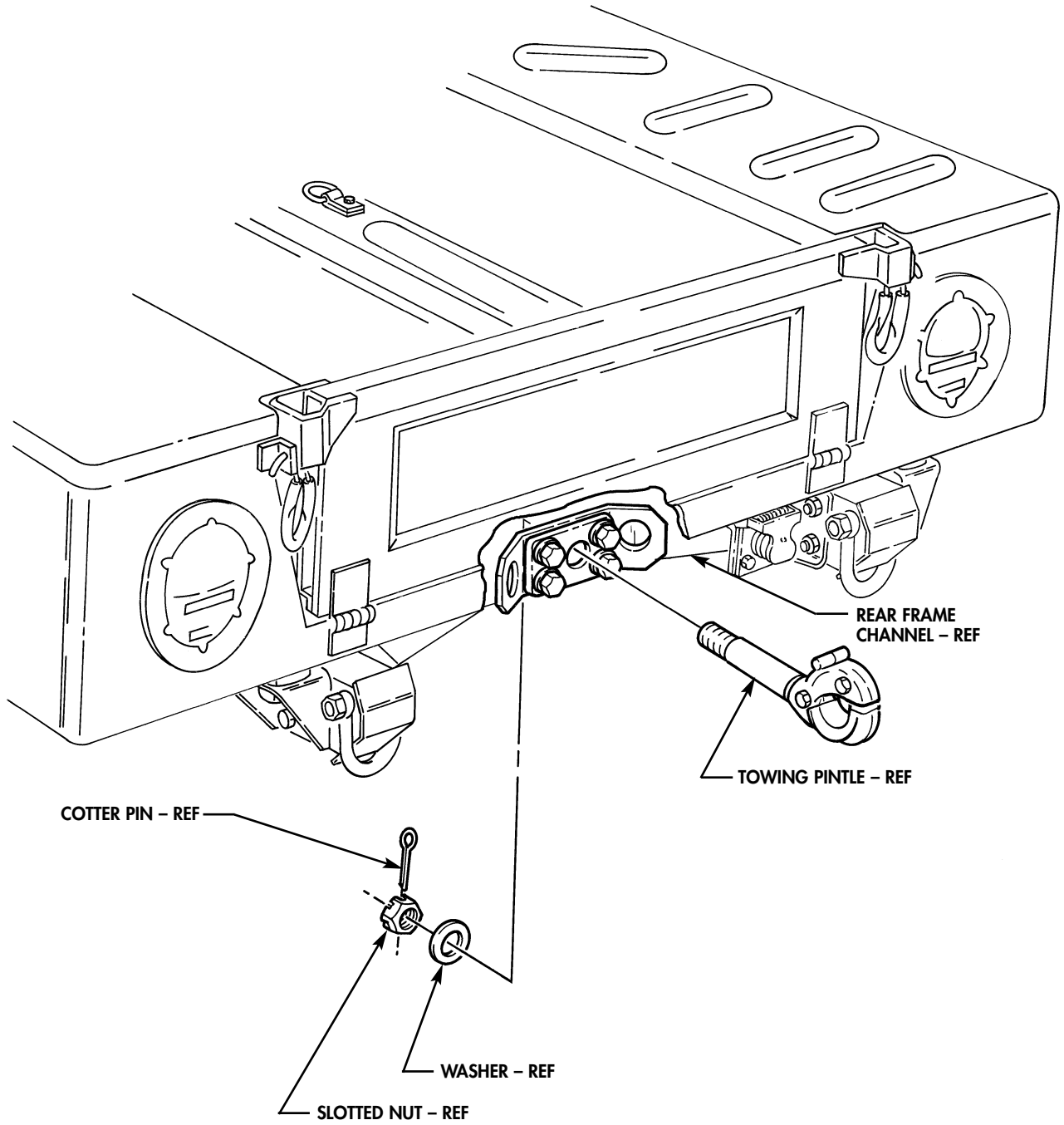

FIGURE 1

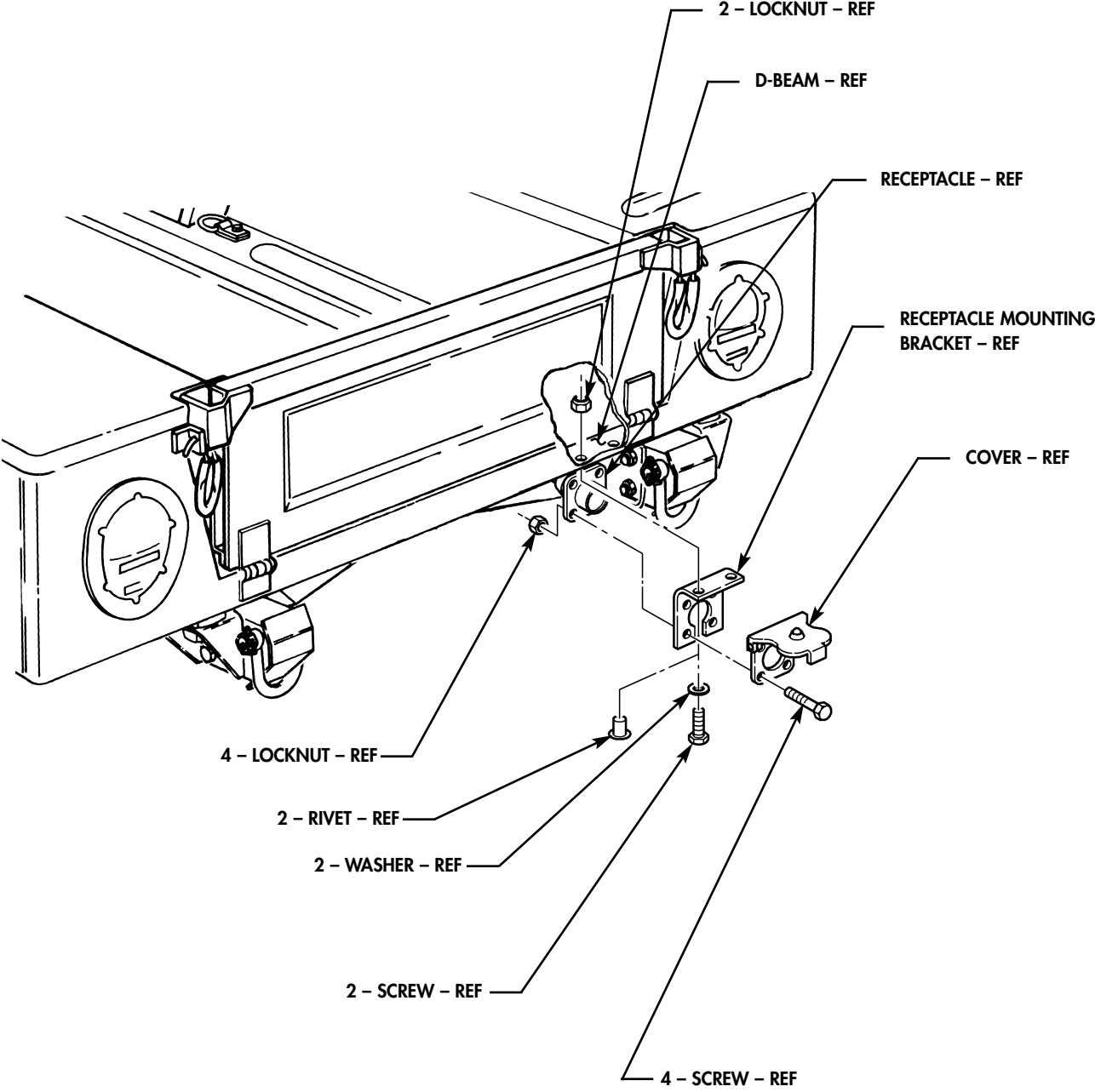

FIGURE 2

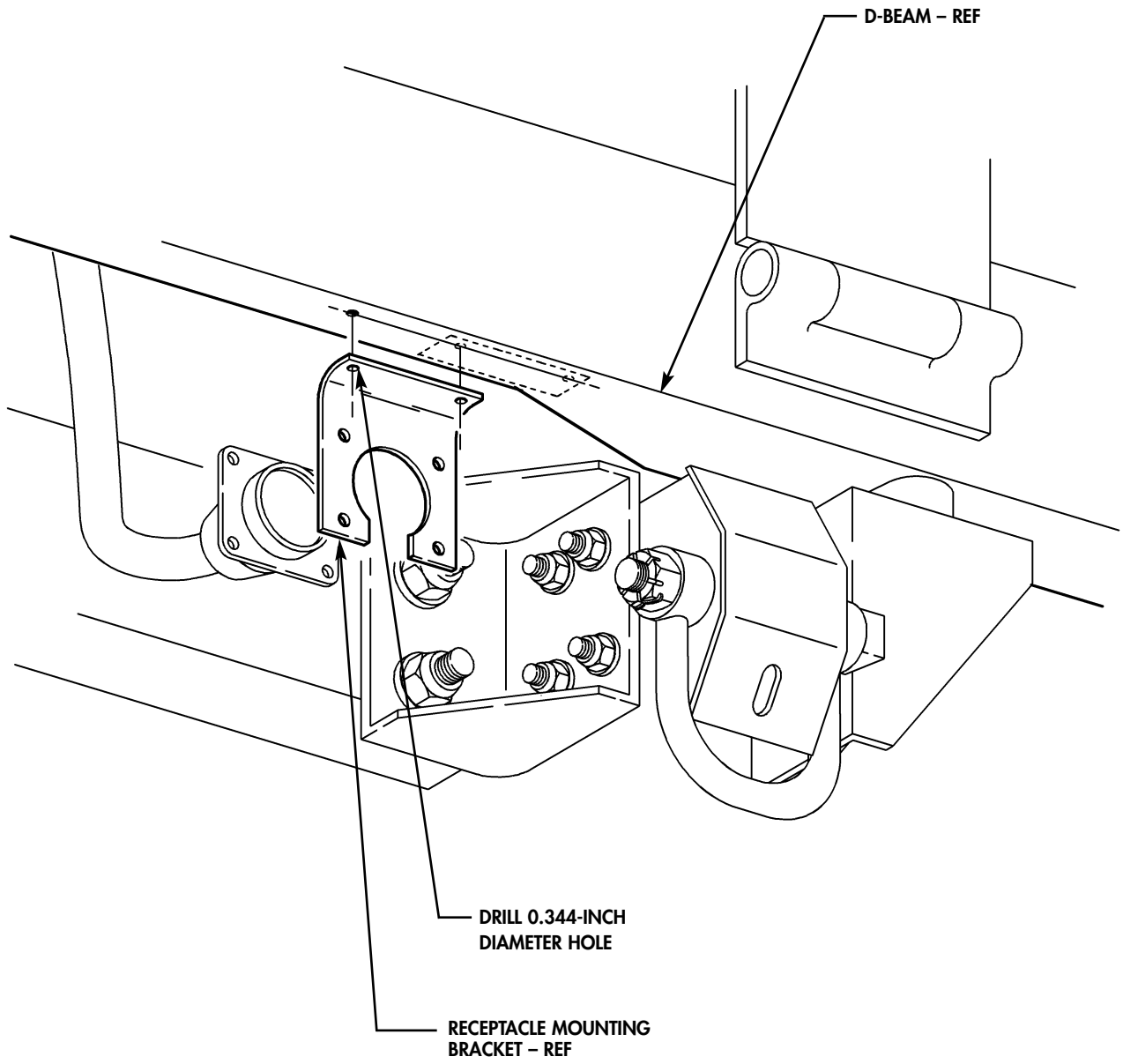

FIGURE 3

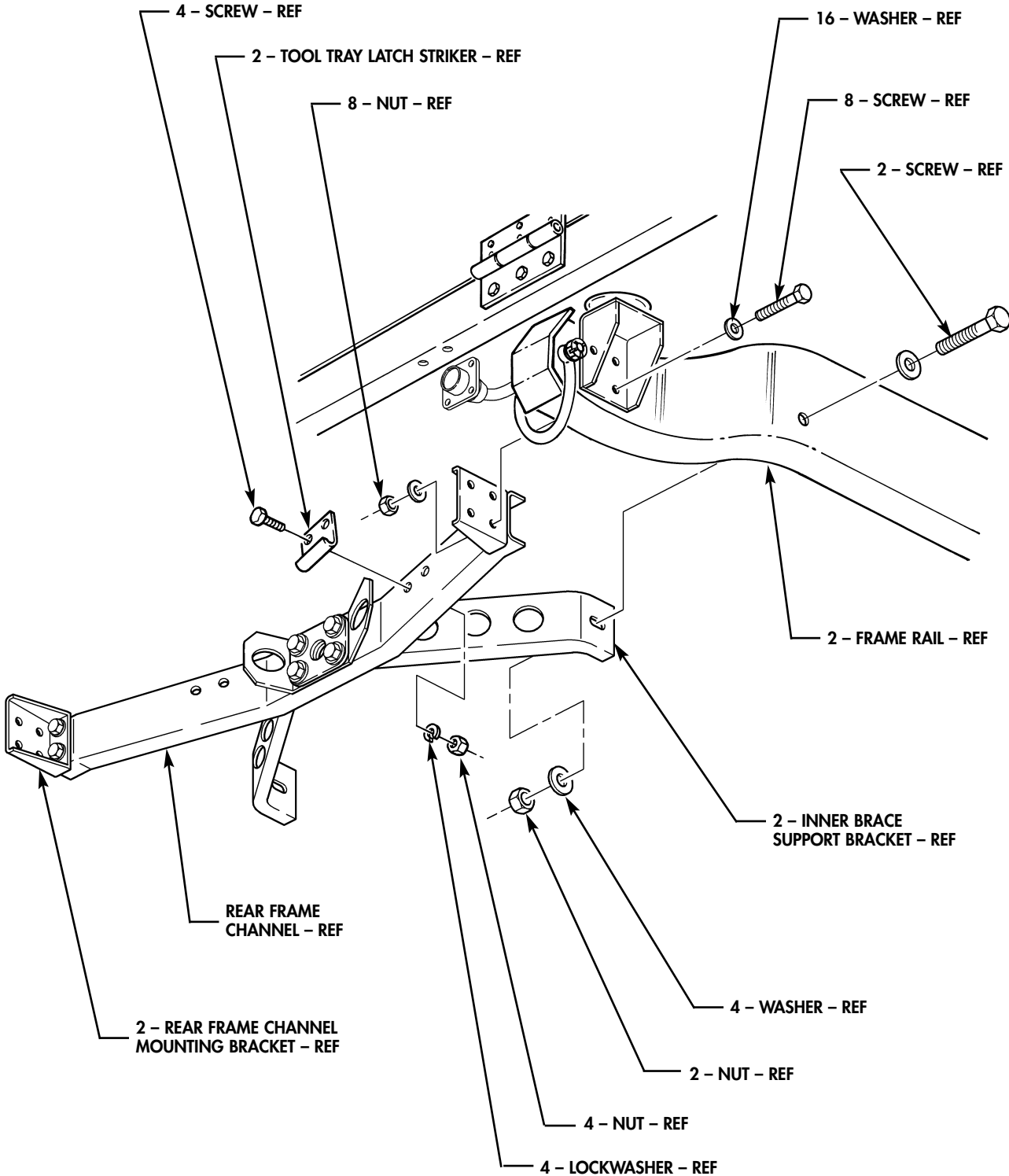

FIGURE 4

NOTE: REMOVE ALL BURRS AND SHARP EDGES

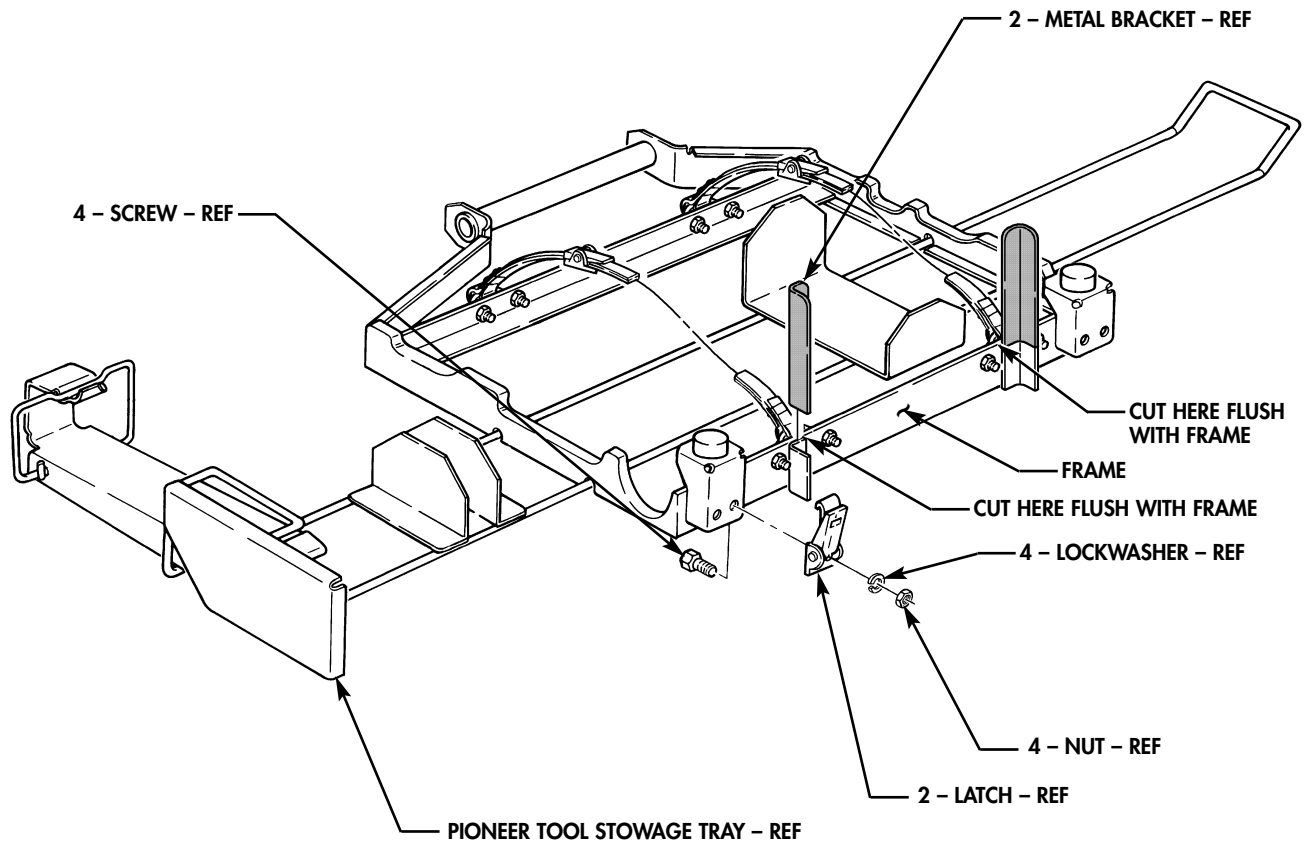

FIGURE 5

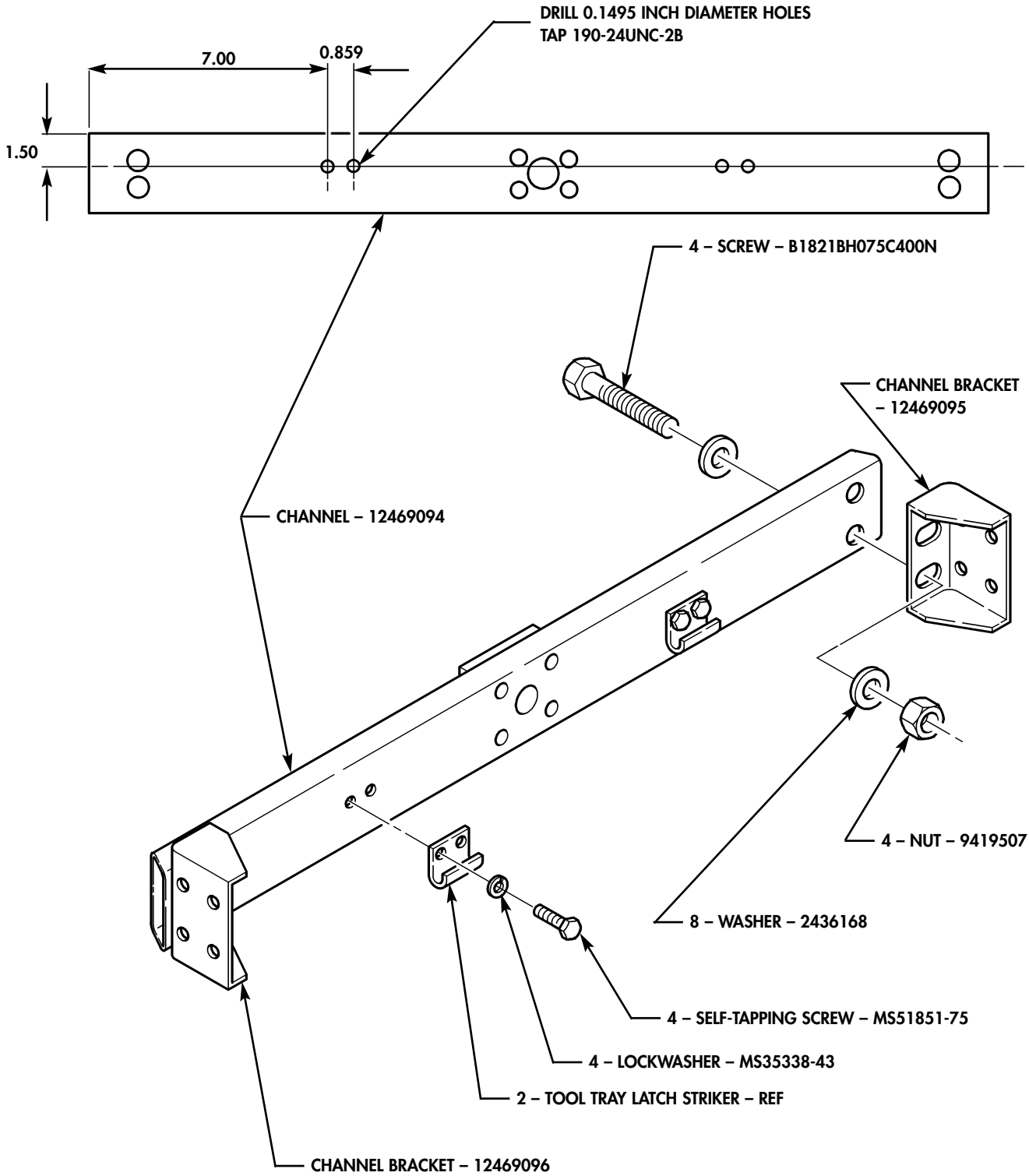

FIGURE 6

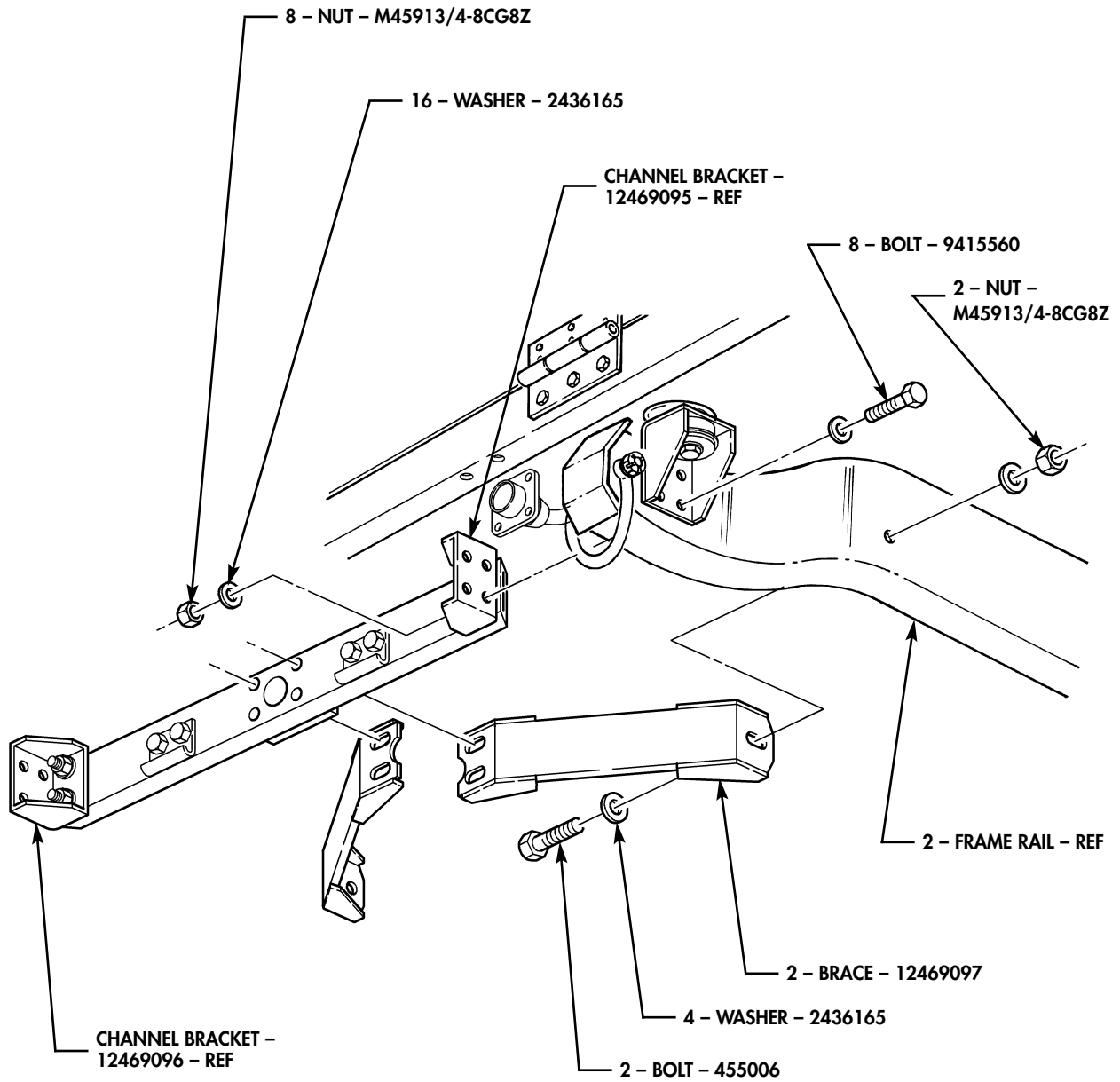

FIGURE 7

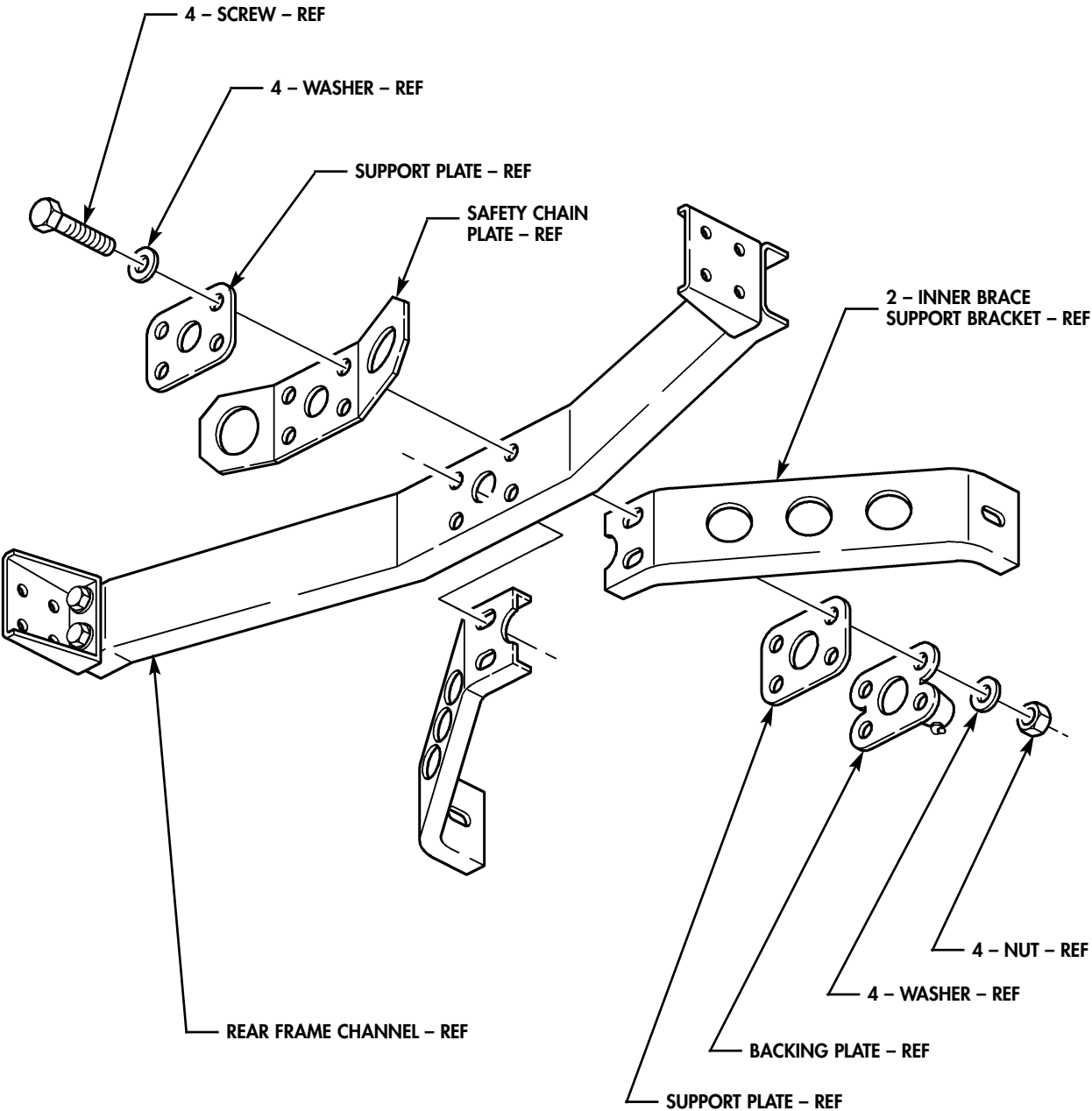

FIGURE 8

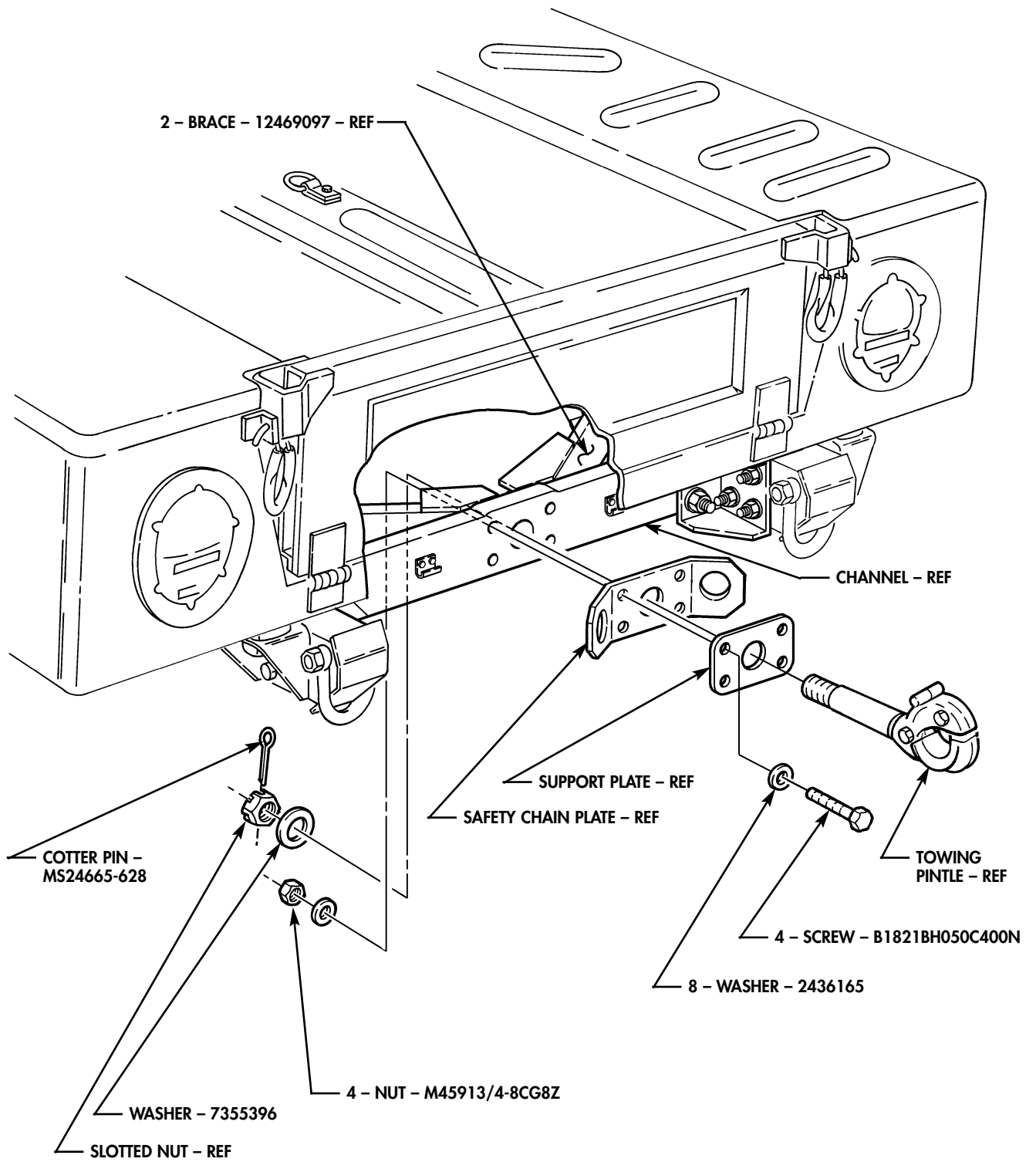

FIGURE 9

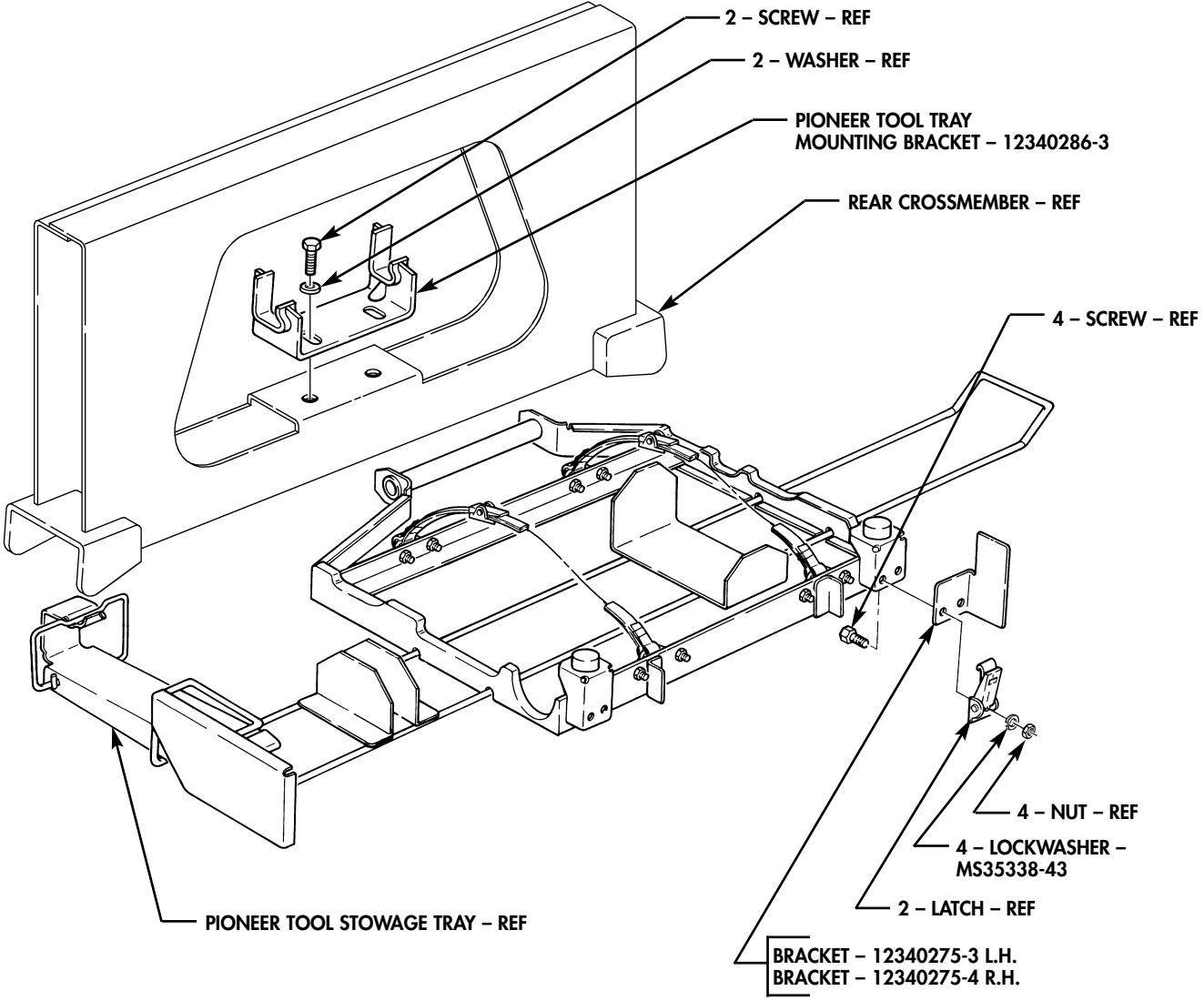

FIGURE 10

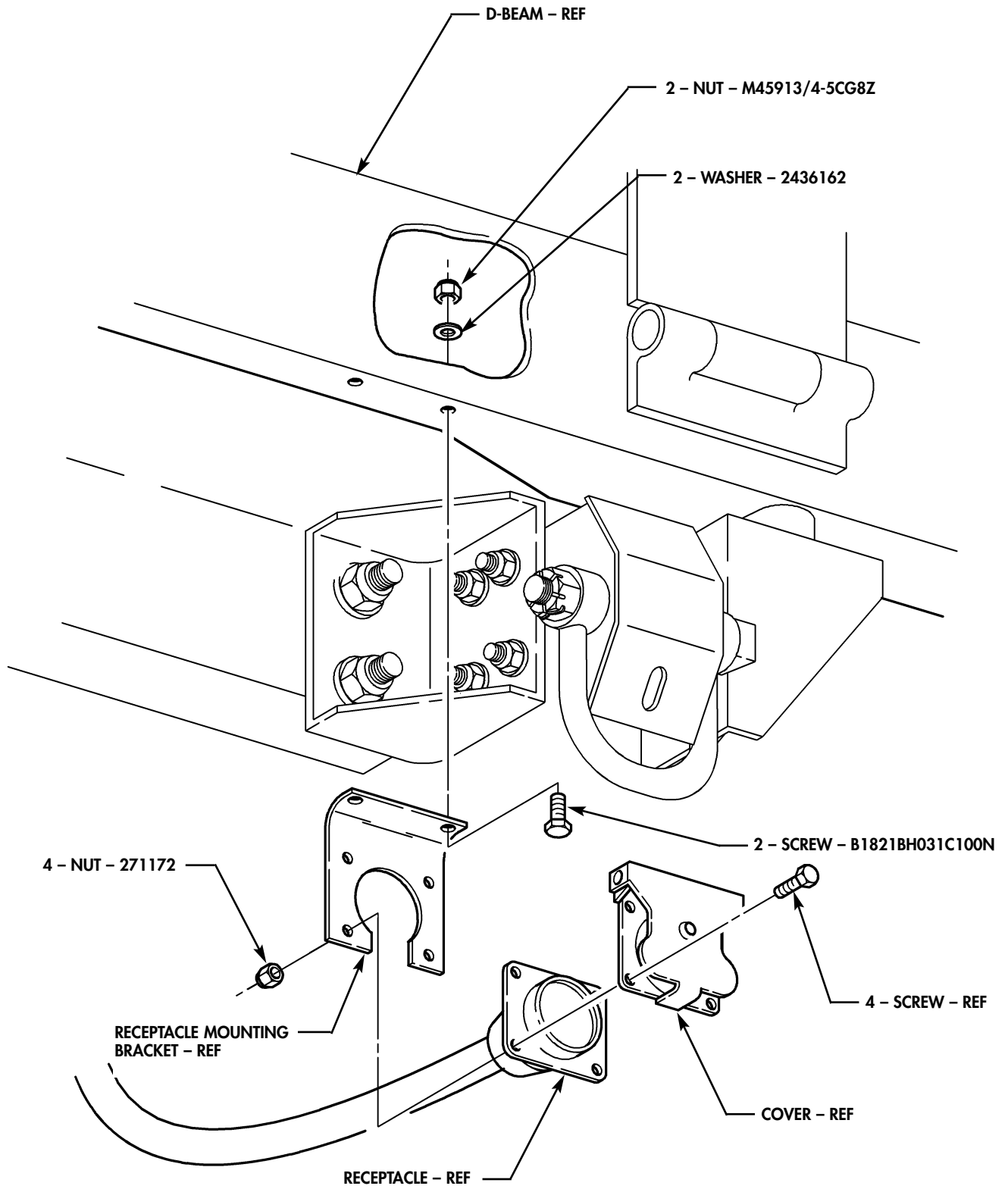

FIGURE 11

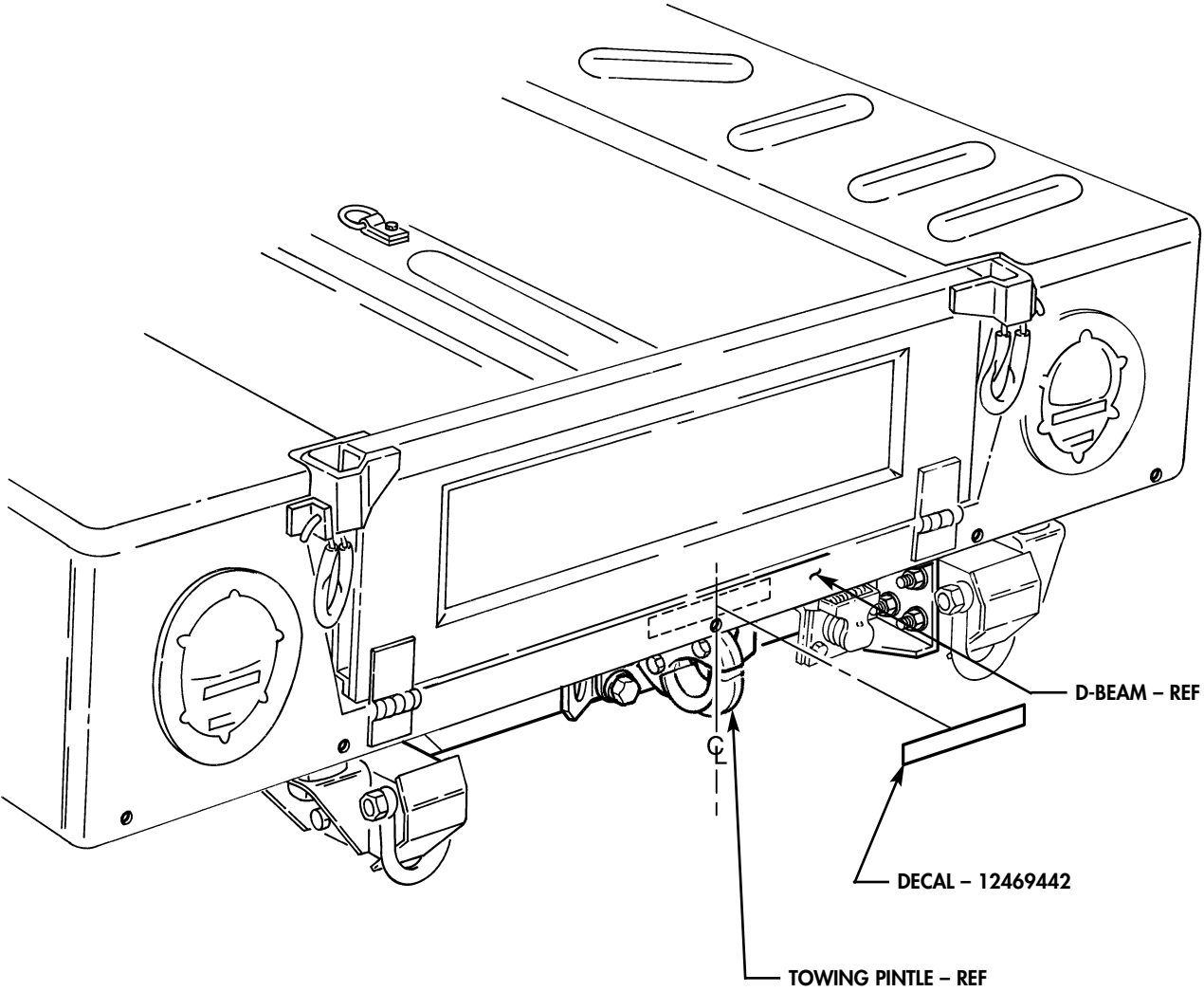

FIGURE 12

NOTE: ALL DIMENSIONS ARE IN INCHES

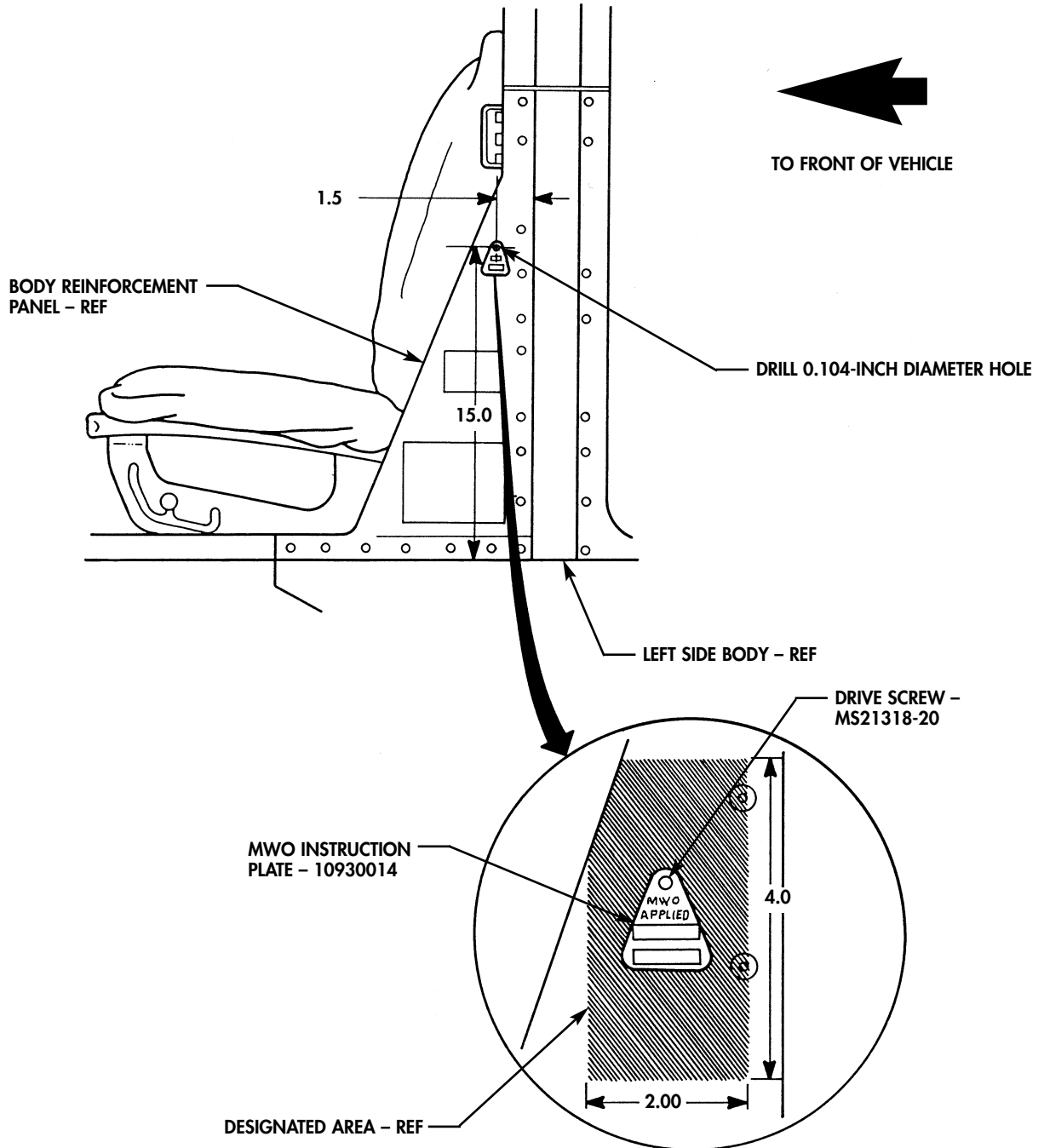
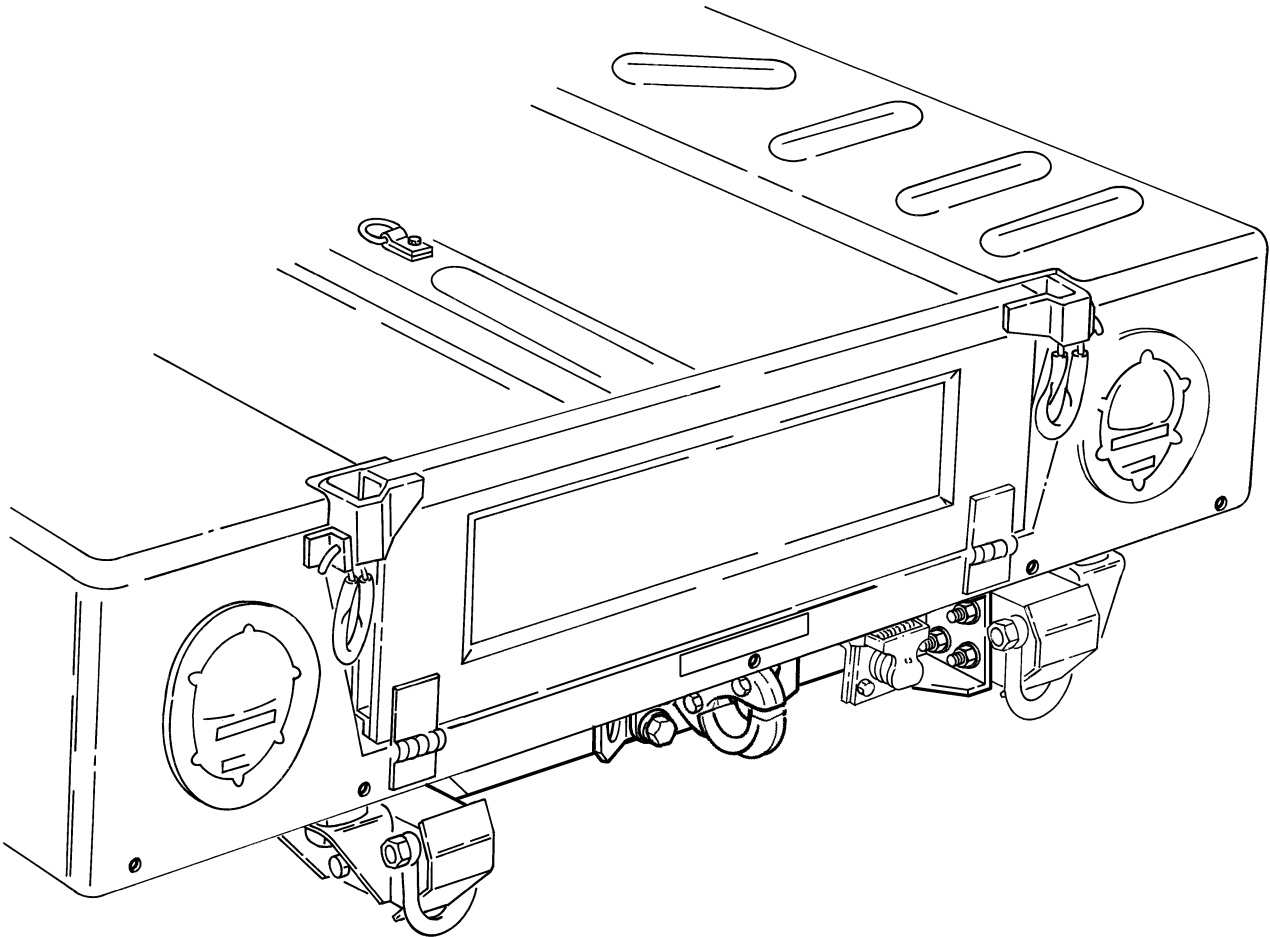

FIGURE 13



CROSSMEMBER REINFORCEMENT INSTALLED

FIGURE 14

MWO 9-2320-280-20-7

By Order of the Secretary of the Army:

ERIC K. SHINSEKI
General, United States Army
Chief of Staff

Official:

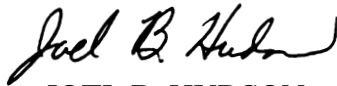

JOEL B. HUDSON
Administrative Assistant to the
Secretary of the Army
0024512

Distribution:

To be distributed in accordance with the initial distribution number (IDN) 381105, requirements for MWO 9-2320-280-20-7.

THE METRIC SYSTEM AND EQUIVALENTS

LINEAR MEASURE

- 1 Centimeter = 10 Millimeters = 0.01 Meters = 0.3937 Inches
- 1 Meter = 100 Centimeters = 1,000 Millimeters = 39.37 Inches
- 1 Kilometer = 1,000 Meters = 0.621 Miles

SQUARE MEASURE

- 1 Sq Centimeter = 100 Sq Millimeters = 0.155 Sq Inches
- 1 Sq Meter = 10,000 Sq Centimeters = 10.76 Sq Feet
- 1 Sq Kilometer = 1,000,000 Sq Meters = 0.386 Sq Miles

CUBIC MEASURE

- 1 Cu Centimeter = 1,000 Cu Millimeters = 0.06 Cu Inches
- 1 Cu Meter = 1,000,000 Cu Centimeters = 35.31 Cu Feet

LIQUID MEASURE

- 1 Milliliter = 0.001 Liters = 0.0338 Fluid Ounces
- 1 Liter = 1,000 Milliliters = 33.82 Fluid Ounces

TEMPERATURE

- $5/9 (^{\circ}\text{F} - 32) = ^{\circ}\text{C}$
- 212° Fahrenheit is equivalent to 100° Celsius
- 90° Fahrenheit is equivalent to 32.2° Celsius
- 32° Fahrenheit is equivalent to 0° Celsius
- $9/5 ^{\circ}\text{C} + 32 = ^{\circ}\text{F}$

WEIGHTS

- 1 Gram = 0.001 Kilograms = 1,000 Milligrams = 0.035 Ounces
- 1 Kilogram = 1,000 Grams = 2.2 Lb
- 1 Metric Ton = 1,000 Kilograms = 1 Megagram = 1.1 Short Tons

APPROXIMATE CONVERSION FACTORS

TO CHANGE	TO	MULTIPLY BY
Inches	Centimeters	2.540
Feet	Meters	0.305
Yards	Meters	0.914
Miles	Kilometers	1.609
Square Inches	Square Centimeters	6.451
Square Feet	Square Meters	0.093
Square Yards	Square Meters	0.836
Square Miles	Square Kilometers	2.590
Acres	Square Hectometers	0.405
Cubic Feet	Cubic Meters	0.028
Cubic Yards	Cubic Meters	0.765
Fluid Ounces	Milliliters	29.573
Pints	Liters	0.473
Quarts	Liters	0.946
Gallons	Liters	3.785
Ounces	Grams	28.349
Pounds	Kilograms	0.454
Short Tons	Metric Tons	0.907
Pound-Feet	Newton-Meters	1.356
Pounds Per Square Inch	Kilopascals	6.895
Miles Per Gallon	Kilometers Per Liter	0.425
Miles Per Hour	Kilometers Per Hour	1.609
TO CHANGE	TO	MULTIPLY BY
Centimeters	Inches	0.394
Meters	Feet	3.280
Meters	Yards	1.094
Kilometers	Miles	0.621
Square Centimeters	Square Inches	0.155
Square Meters	Square Feet	10.764
Square Meters	Square Yards	1.196
Square Kilometers	Square Miles	0.386
Square Hectometers	Acres	2.471
Cubic Meters	Cubic Feet	35.315
Cubic Meters	Cubic Yards	1.308
Milliliters	Fluid Ounces	0.034
Liters	Pints	2.113
Liters	Quarts	1.057
Liters	Gallons	0.264
Grams	Ounces	0.035
Kilograms	Pounds	2.205
Metric Tons	Short Tons	1.102
Newton-Meters	Pound-Feet	0.738
Kilopascals	Pounds Per Square Inch	0.145
Kilometers Per Liter	Miles Per Gallon	2.354
Kilometers Per Hour	Miles Per Hour	0.621

